



## ENHANCED RELIABILITY

Human error reduced thanks to its simplicity.  
Easy-to-use gauge carrier operated by anyone in less than 10 mins.  
Proofed for Tubing-Conveyed Perforating.

## METROLOG BREAKTHROUGH

Gauges protected and insulated from vibrations.  
Carriers can hold up to 6 gauges (Quartz or Piezoresistive).  
Monitor both casing and tubing pressure at the same time.

## APPLICATIONS

Drill Stem Testing and TCP.  
Any reservoir enhancement and workover jobs: acidizing, fracturing, gravel pack, etc.

## SPECIFICATIONS

### MECHANICS

Material	Stainless steel (parkerised)		
Sour service	NACE recommendations		
Min. ID / OD	1" / 4"		
Std. ID / OD	2"¼ / 5"		
Max. ID / OD	3" / 7"		
Working press.	Up to 15.000 psi		
Threads	Any standard threads (ex: 3"½ IF BUxPD) or any premium threads		

### TYPE

	For Tubing Pressure Full Bore internal	For Casing Pressure Full Bore internal	Mixed Tubing/Casing
Up to # iGauges	6	4	4
Up to # iQuartz	6	4	4



### STANDARD DIMENSIONS

	With iGauges	With iQuartz
Length	2 ft	3 ft
Weight	50 lbs	70 lbs

### Metrolog, a Sercel Brand

1110 Avenue l'Occitane, Technoparc, Bât.2, C.S. 17619. 31676 Labège Cedex FRANCE

Telephone: (33) 5 61 34 80 74. Fax: (33) 5 61 20 41 31. E-mail: sales@metrolog.com

[www.metrolog.com](http://www.metrolog.com)

### Sercel

S.A. au capital de 2 000 000 €. Siège Social: 16 rue de Bel-Air 44470 Carquefou.  
378.040.497 R.C.S. Nantes. Code APE 2651B

[www.sercel.com](http://www.sercel.com)

Printed in France. © Sercel 02/12 - Information subject to change without notice. TDS0\_007\_B



## CARRIER 2 3/8 OD

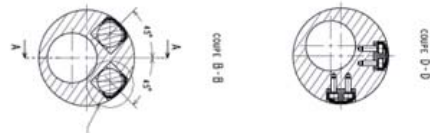
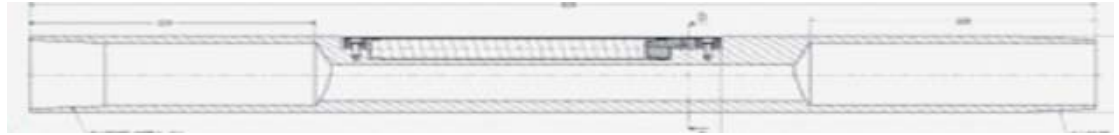

2 3/8 EUE threads

## CARRIER 2 7/8 OD

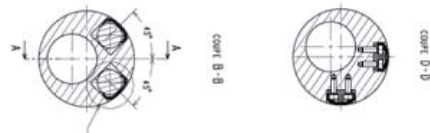
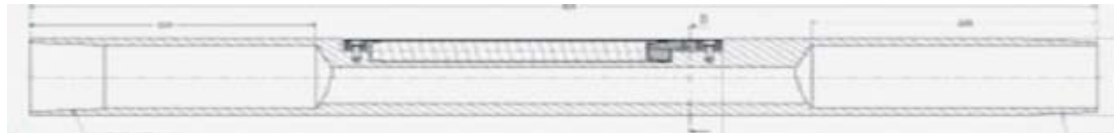

2 7/8 Hydrill PH6 threads

## CARRIER 3 7/8" OD

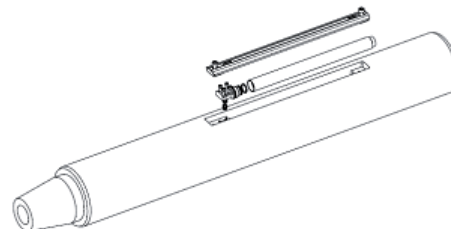
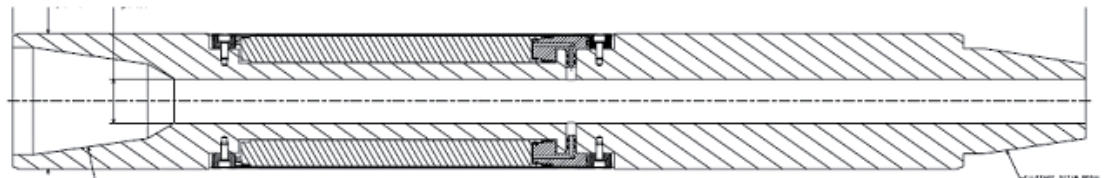

### Metrolog, a Sercel Brand

1110 Avenue l'Occitane, Technoparc, Bât.2, C.S. 17619. 31676 Labège Cedex FRANCE

Telephone: (33) 5 61 34 80 74. Fax: (33) 5 61 20 41 31. E-mail: sales@metrolog.com

[www.metrolog.com](http://www.metrolog.com)

### Sercel

S.A. au capital de 2 000 000 €. Siège Social: 16 rue de Bel-Air 44470 Carquefou.

378.040.497 R.C.S. Nantes. Code APE 2651B

[www.sercel.com](http://www.sercel.com)

Printed in France. © Sercel 06/13 - Information subject to change without notice. TDSO\_007\_B



**GAUGE CARRIER FOR FRAC PACK**

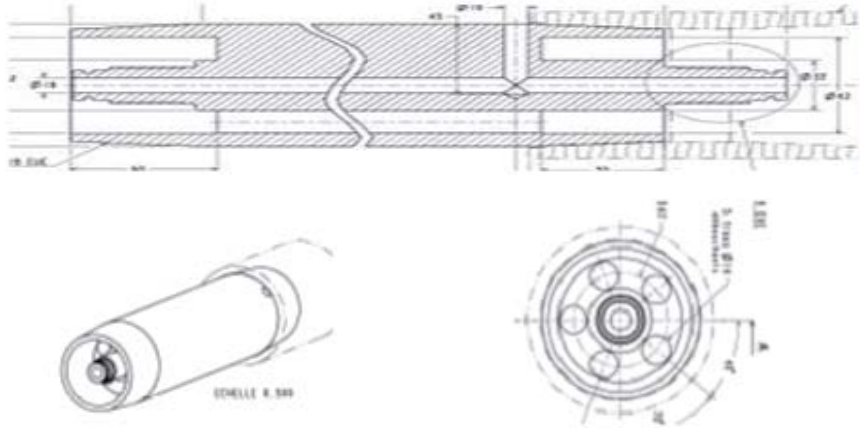

**EXTERNAL GAUGE CARRIER 5" OD \* 2.25 ID (FBE)**

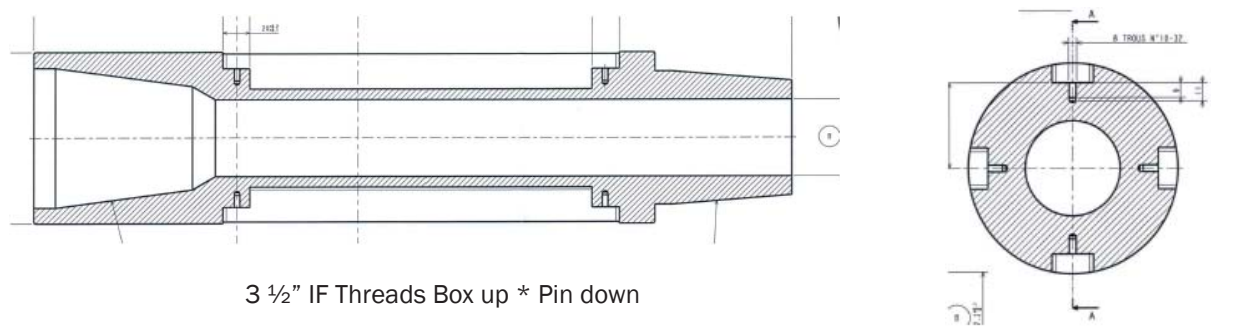

**INTERNAL GAUGE CARRIER 5" OD \* 2.25 ID (FBI)**

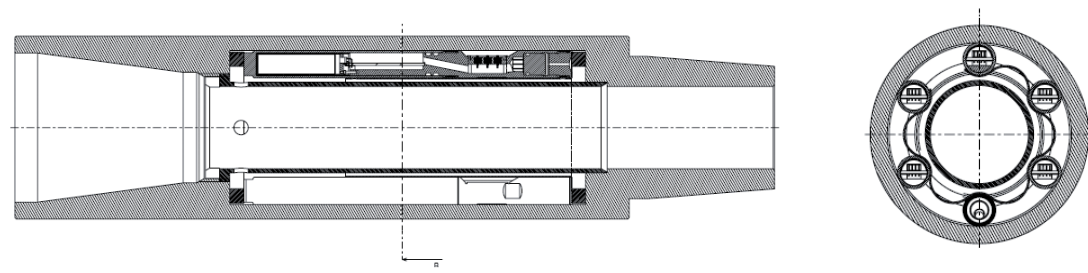

3 1/2 IF Box up & Pin down

**Metrolog, a Sercel Brand**

1110 Avenue l'Occitane, Technoparc, Bât.2, C.S. 17619. 31676 Labège Cedex FRANCE

Telephone: (33) 5 61 34 80 74. Fax: (33) 5 61 20 41 31. E-mail: sales@metrolog.com

[www.metrolog.com](http://www.metrolog.com)

**Sercel**

S.A. au capital de 2 000 000 €. Siège Social: 16 rue de Bel-Air 44470 Carquefou.

378.040.497 R.C.S. Nantes. Code APE 2651B

[www.sercel.com](http://www.sercel.com)

Printed in France. © Sercel 06/13 - Information subject to change without notice. TDSO\_007\_B